

Dixie Caps

G&K makes purchasing Handrail Extrusions easy and painless. We have a multitude of shapes including Mechanical Railing, Stock Welded Caps, Dixie Caps, Pipe & Wall Brackets; as well as Special Order Railings, Posts and Caps. Our four nationwide distribution centers will ship your standard or custom Aluminum extrusions efficiently and economically with our “**Just-In-Time**” delivery. Call the G&K nearest you today for quick and reliable service!



Dixie 28-63-100

154

accepts 1" & 1 1/4" Channels
wt/ft: 0.523; length: 20'

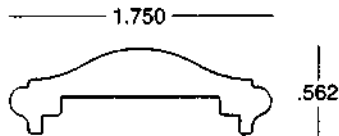

Dixie 28-63-110

156

accepts 1", 1 1/4" & 1 1/2" Channels
wt/ft: 0.668; length: 20'

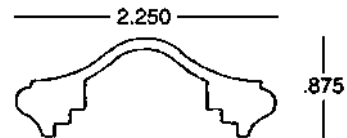

Dixie 28-63-105

155

accepts 1 1/2" Channels
wt/ft: 0.413; length: 20'

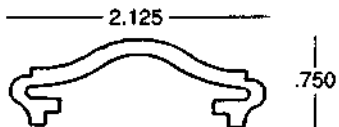

Dixie 28-63-230

158

accepts 1 1/4" & 1 1/2" Channels
wt/ft: 1.180; length: 20'

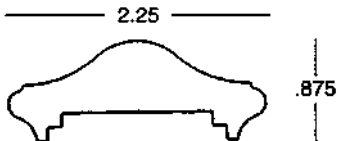



Stock Welded Caps

G&K makes purchasing Handrail Extrusions easy and painless. We have a multitude of shapes including Mechanical Railing, Stock Welded Caps, Dixie Caps, Pipe & Wall Brackets; as well as Special Order Railings, Posts and Caps. Our four nationwide distribution centers will ship your standard or custom Aluminum extrusions efficiently and economically with our “**Just-In-Time**” delivery.

Call the G&K nearest you today for quick and reliable service!

2 5/8” Hollow Cap **129**

accepts 3/4” Picket with 2” Post

28-63-210

wt/ft: 0.573; length: 25’ 10”

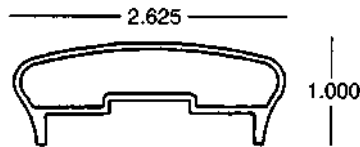

2” x 1” Hollow Cap **131**

accepts 3/4” Picket with 1 1/2” Post

28-63-275

wt/ft: 0.437; length: 20’

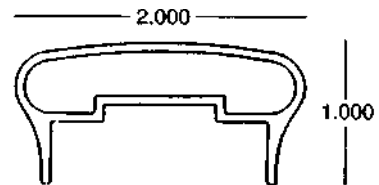

2 5/8” Solid Cap **130**

accepts 3/4” & 1” Picket with 2” Post

28-63-200

wt/ft: 0.530; length: 25’ 10”

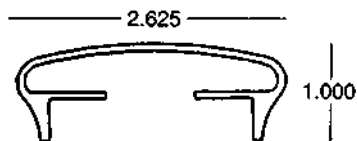

Handicap Grip Rail **132**

accepts 3/4” Picket with 1 1/4” Post

52-63-1641

wt/ft: 0.665; length: 20’

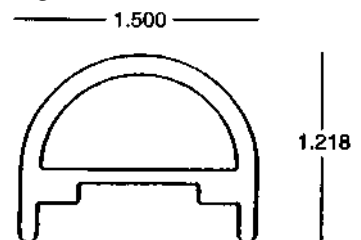

Outside Sleeve**133***mates with #129 and #130***2 5/8" 28-63-220**

wt/ft: 0.732 length: 20'

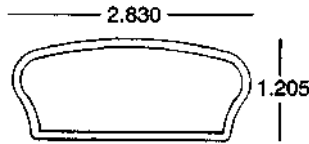
**2 1/4" x 4" Insert****138***mates with #139 and #140***28-63-257**

wt/ft: 1.028; length: 10'

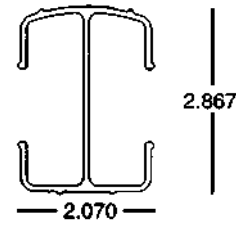
**2 5/8" 28-63-215****135***accepts 3/4" Picket with 2" Post**mates with #136*

wt/ft: 0.670; length: 25' 10"

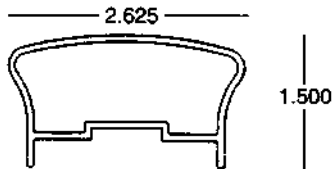
**28-63-255****139***(less radius) accepts 3/4" Picket with 2" Post*

wt/ft: 1.345; length: 24'

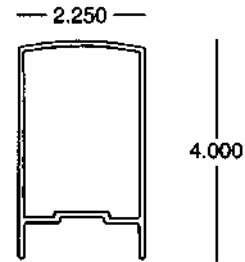
**Inner Splice****136***mates with #135***2 5/8" 28-63-208**

wt/ft: 0.344; length: 10'

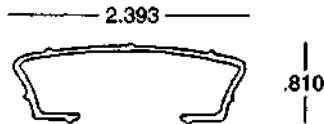
**28-63-256****140***(more radius) accepts 3/4" Picket with 2" Post*

wt/ft: 1.223; length: 24'

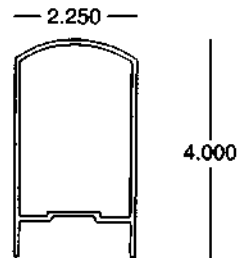
**Outside Sleeve****137***mates with #135***2 5/8" 28-63-225**

wt/ft: 0.840 length: 20'

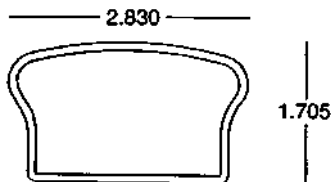
**Outside Sleeve***mates with #147***Mill Order****148**

wt/ft: 0.941

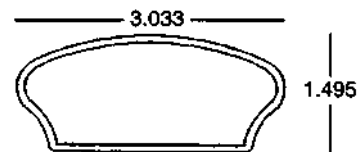

28-63-265

149

accepts 3/4" Picket; accepts 2" Post
mates with #150 and #151
wt/ft: 0.998; length: 24'

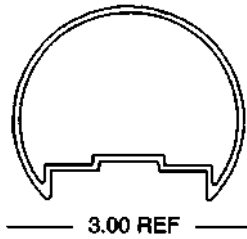

Inside Sleeve

150

mates with #149

40-63-701

wt/ft: 0.718; length: 10'

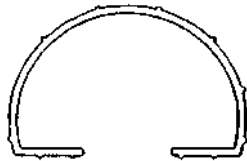

Outside Sleeve

151

mates with #149

28-63-263

wt/ft: 1.042; length: 10'

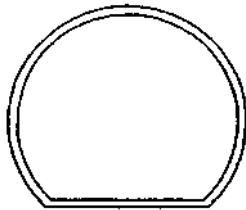

28-63-285

152

accepts 3/4" Picket ; accepts 1 1/2"
and 2" Post
wt/ft: 1.088; length: 24'

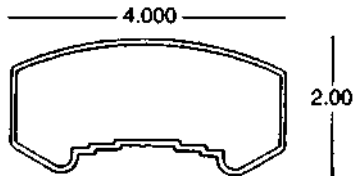

Railing Channel (*with welding legs*) 6063-T5

<u>Stock Code</u>	<u>Size in Inches</u>	<u>Approx. Wt/Lin ft.</u>
13-63-300	1 1/2 x 1 x .093/.56 x 25' (receives .750 picket)	0.322
13-63-305	1 1/2 x 12' Channel Cover Plate	0.169
13-63-264	1 3/4 x 3/4 x .093/.062 x 24' (receives .750 picket)	0.330
Mill Order	1 3/4 Channel Cover Plate	0.168
13-63-261	2 x 7/16 x .093 x 25' 2" (no legs)	0.294
13-63-262	2 x 3/4 x .125/.090 x 23' 10" (no legs)	0.440
13-63-266	2 x 1 x .093/.056 x 25' (receives .750 picket)	0.395
13-63-227	2 x 16' Channel Cover Plate	0.166



Handrailing 10

**Special Order:
Railing, Posts, and Caps**

G&K makes purchasing Handrail Extrusions easy and painless. We have a multitude of shapes including Mechanical Railing, Stock Welded Caps, Dixie Caps, Pipe & Wall Brackets; as well as Special Order Railings, Posts and Caps. Our four nationwide distribution centers will ship your standard or custom Aluminum extrusions efficiently and economically with our "Just-In-Time" delivery. Call the G&K nearest you today for quick and reliable service!



Mill Order **1**
accepts 3/4" Picket and 1 1/2" Post
wt/ft: 0.918

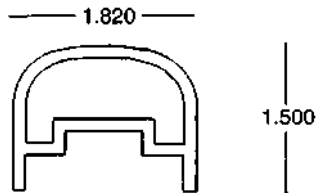

28-63-027 **4**
accepts 2" Channel and 2" Post
wt/ft: 1.312

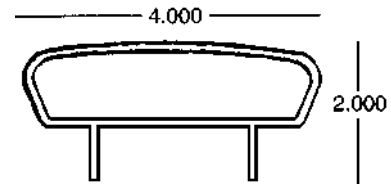

Mill Order **2**
accepts 3/4" Picket and 1 3/4" Post
wt/ft: 0.708

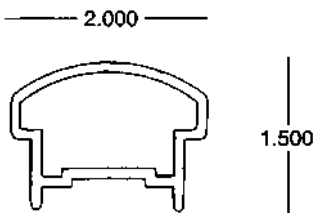

Mill Order **6**
accepts 3/4" Picket and 2" Post
wt/ft: 1.598

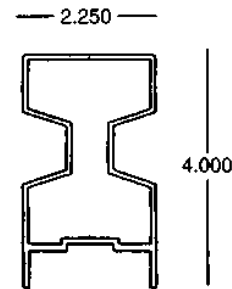

28-63-240

8

accepts 3/4" Picket and 1 1/2" Post
wt/ft: 1.208; length: 25' 10"

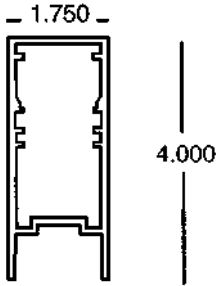

Inside Sleeve

18

Mill Order
mates with #17
wt/ft: 0.776

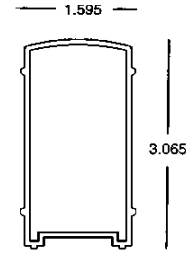

Mill Order

11

accepts 3/4" Picket and 2" Post
wt/ft: 0.605

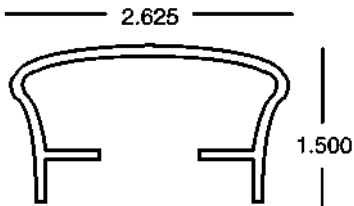

Mill Order

20

accepts 3/4" Picket and 2" Post
wt/ft: 1.805

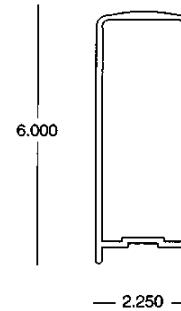

Mill Order

12

accepts 3/4" Picket and 1 1/2" Post
wt/ft: 0.576

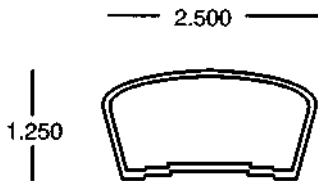

Outside Sleeve

22

Mill Order
mates with #21
wt/ft: 0.768

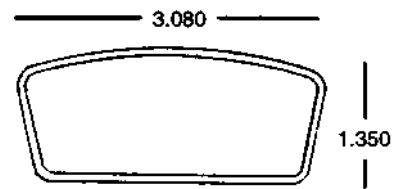

Mill Order

14

accepts 2" Post; mates with #16
wt/ft: 1.224

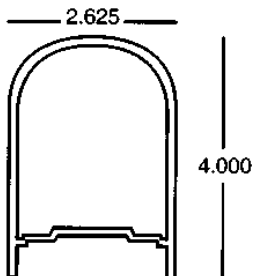

28-63-031 (G&K NC)

27

accepts 3/4" and 1" Picket; 2" Post
wt/ft: 1.958

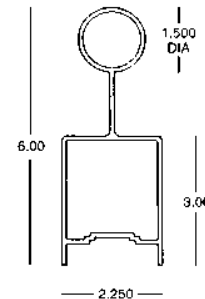

Mill Order **31**
accepts 3/4" Picket and 1 1/2" Post
 wt/ft: 1.478

Mill Order **37**
mates with #38
 wt/ft: 1.131

Mill Order **34**
accepts 3/4" Picket and 1 3/4" Post
 wt/ft: 2.367

28-63-260 **38**
accepts 3/4" Picket and 2" Post
 wt/ft: 1.799

Mill Order **35**
accepts 3/4" Picket and 1 3/4" Post
 wt/ft: 1.820

28-63-012 **39**
accepts 3/4" Picket and 2" Post
 wt/ft: 1.582

Mill Order **36**
accepts 3/4" Post
 wt/ft: 1.644

Mill Order **43**
accepts 3/4" Picket and 2" Post
 wt/ft: 1.695

Mill Order

44

accepts 3/4" Picket and 2" Post

wt/ft: 1.762

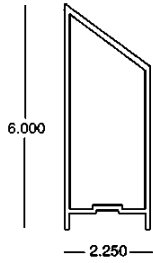

Mill Order

45

accepts 3/4" Picket and 2" Post

wt/ft: 1.136

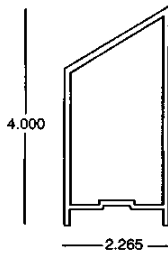

Top Cap IR-1

46

Mill Order

accepts 2" Post; mates with #47

wt/ft: 0.452; length: 24'

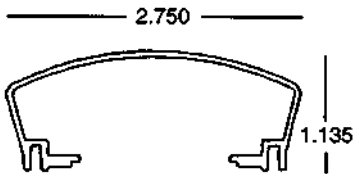

Top Cap IR-4

49

Mill Order

accepts 2" Post mates with #47

wt/ft: 1.216; length: 24'

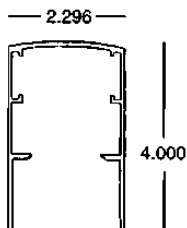

28-63-300 **153**
accepts 3/4" Picket; accepts 1 1/2" Post
wt/ft: 0.582; length: 20'

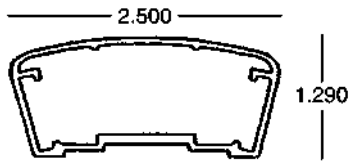

28-63-260 ***144**
accepts 3/4" Picket & 2" Post
mates with #146
wt/ft: 1.740; length: 24'

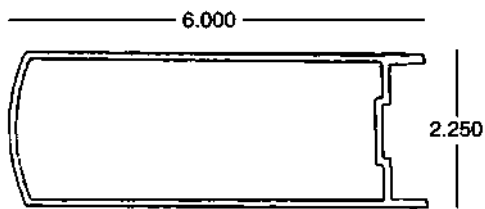

Inside Sleeve **146**
52-63-4868
mates with #38
wt/ft: 1.269 length: 10'

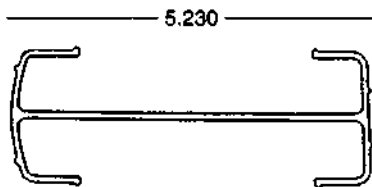

Glass Railing Offset 1

Mill Order
mates with #3
wt/ft: 1.563

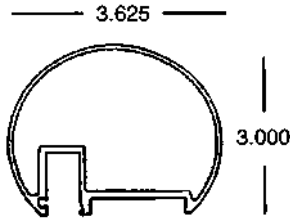

Glass Railing Offset Rail 12

Mill Order
wt/ft: 1.807

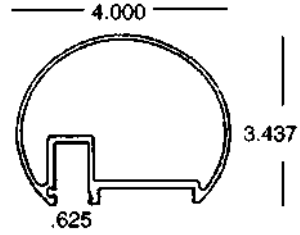

Glass Railing 2

Mill Order
accepts 1/4" Glass and 2 1/2" Post
wt/ft: 1.701

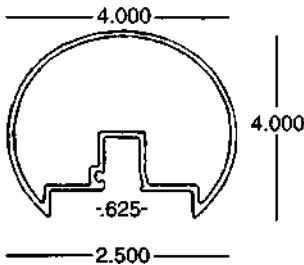

Glass Rail 14

Mill Order
accepts 1" Post;
wt/ft: 1.747

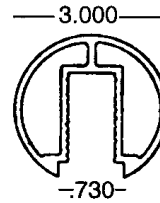

Glass Railing Inside Sleeve 3

Mill Order
mates with #1
wt/ft: 0.853

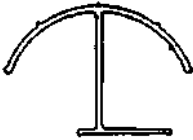

Bottom Molding Glass Shoe

Mill Order
wt/ft: 7.969

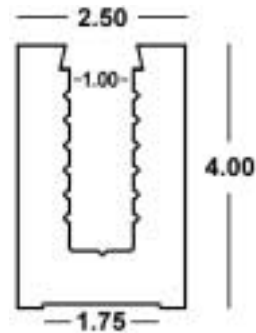

Glass Railing Bottom Channel 4

Mill Order
accepts 1/4" Glass
wt/ft: 1.019

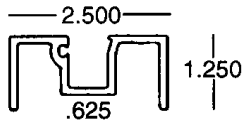

Bottom Molding Glass Shoe

Mill Order
wt/ft: 6.473

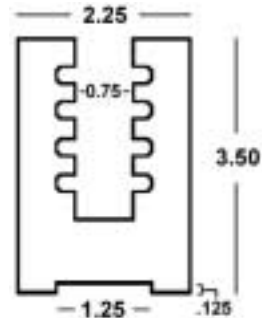

Mill Order

wt/ft: 1.122

1

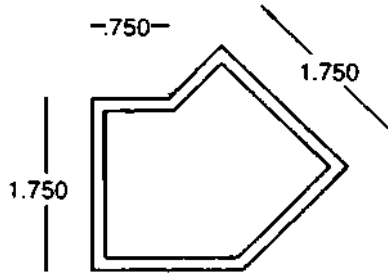

Quik Rok

61-00-001

Anchoring Cement

Available in 5 Gallon Buckets

52-63-2033

45 degree Post x 20'

wt/ft: 1.041

2

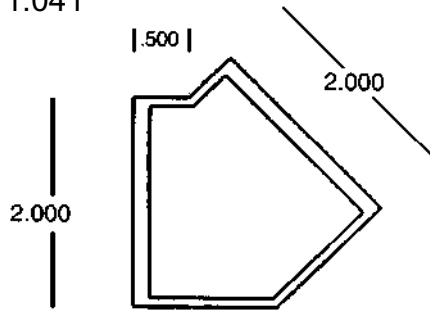

Mechanical Railing

G&K makes purchasing Handrail Extrusions easy and painless. We have a multitude of shapes including Mechanical Railing, Stock Welded Caps, Dixie Caps, Pipe & Wall Brackets; as well as Special Order Railings, Posts and Caps. Our four nationwide distribution centers will ship your standard or custom Aluminum extrusions efficiently and economically with our “Just-In-Time” delivery. Call the G&K nearest you today for quick and reliable service!



Top Cap

HR-1

mates with HR-2; bundle of 8

HR-1-WH (x20') White

HR-1-BR (x20') Bronze

52-63-5578 (x25') Black

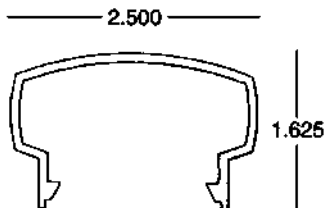

Bottom Channel

HR-3

mates with HR-2; bundle of 8

HR-3-WH (x19' 6") White

HR-3-BR (x19' 6") Bronze

52-63-4609 (x25') Black

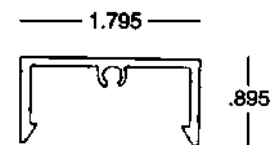

Snap Plate

HR-2

mates with HR-1, 3, 4, 4A, 4C, 6, 7, 8, 14; bundle of 12

HR-2-WH (x21' 1") White

HR-2-BR (x21' 1") Bronze

HR-2-BK (x21' 1") Black

HR-2-WH-2 (x23') White

HR-2-BR-2 (x23') Bronze

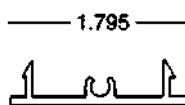

Snap Plate (continued)

HR-2

mates with HR-1, 3, 4, 4A, 4C, 6, 7, 8, 14; bundle of 12

52-63-6147 (x19' 6") White (G&K FL)

52-63-6149 (x19' 6") Bronze (G&K FL)

HR-2B-WH (x23') White (G&K FL)*

HR-2B-MB (x23') Bronze (G&K FL)*

w/Picket Slot; no screw grooves

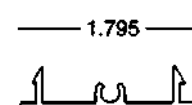

Snap Post**HR-4***mates with HR-2; bundle of 6*

- HR-4-WH (x21' 1") White
- HR-4-WH-2 (x23') White
- HR-4-BR (x21' 1") Bronze
- HR-4-BR-2 (x23') Bronze

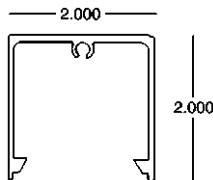
**Snap Post** (continued)**HR-4***mates with HR-2; bundle of 6*

- 52-63-6146 (x19' 6") White (G&K FL)
- 52-63-6148 (x19' 6") Bronze (G&K FL)

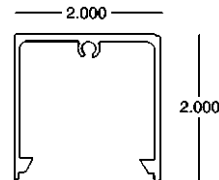
**Snap Post****HR-4A***mates with HR-2; bundle of 6*

- HR-4A-WH (x21' 1") White
- HR-4A-BR (x21' 1") Bronze
- HR-4A-BK (x25') Black

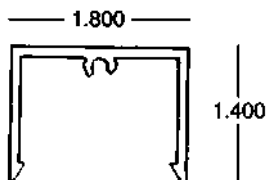
**Top Cap****HR-10***mates with HR-11A; bundle of 8*

- HR-10-WH (x20') White
- HR-10-BR (x20') Bronze
- HR-10-BK (x20') Black

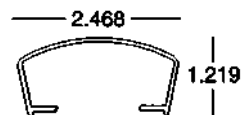
**Bottom Channel****HR-12A***bundle of 20*

- HR-12A-WH (x19' 6") White
- HR-12A-BR (x19' 6") Bronze

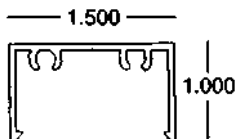
**Snap Plate****HR-11A***(uses 3/4" or 1" Picket)**mates with HR-10; uses HR-5, HR-13; bundle of 12*

- HR-11A-WH (x20') White
- HR-11A-BR (x20') Bronze
- HR-11A-BK (x20') Black

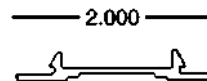

**1" Picket****HR-5***bundle of 20*

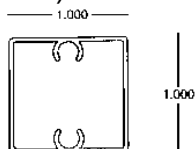
- HR-5-WH (x23') White
- HR-5-WH-1 (x19' 1") White (G&K FL)
- HR-5-BR (x23') Bronze
- HR-5-BR-1 (x19' 1") Bronze (G&K FL)
- HR-5-BK (x23' 6") Black

**3/4" Picket****HR-13***bundle of 20*

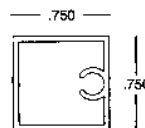
- HR-13-WH (x22' 5") White
- HR-13-WH-1 (x19' 1") White (G&K FL)
- HR-13-BR (x22' 5") Bronze
- HR-13-BR-1 (x19' 1") Bronze (G&K FL)
- HR-13-BK (x19' 1") Black (G&K FL)

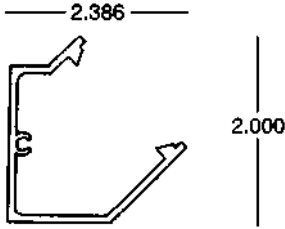
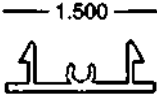
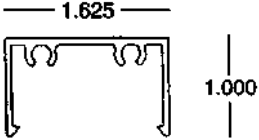
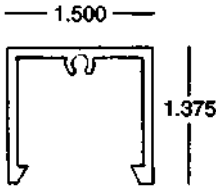
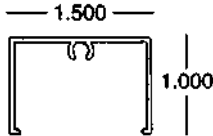
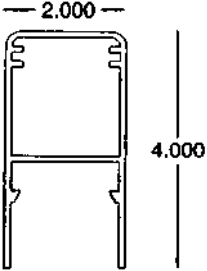
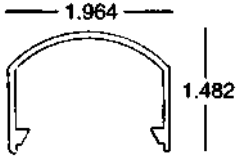

<p>Corner Post HR-4C <i>mates with HR-2</i> Mill Order</p> 	<p>Snap Plate HR-15 <i>mates with HR-16; bundle of 16</i> HR-15-WH-1 (x18' 6") White HR-15-BR-1 (x18' 6") Bronze</p> 
<p>Snap Channel HR-12 <i>bundle of 12</i> HR-12-WH (x19' 6") White HR-12-BR (x19' 6") Bronze HR-12-BK (x19' 6") Black</p> 	<p>Snap Post HR-16 <i>mates with HR-15; bundle of 8</i> HR-16-WH-1 (x18' 6") White HR-16-BR-1 (x18' 6") Bronze</p> 
<p>Bottom Channel HR-12B <i>bundle of 12</i> HR-12B-WH (x19' 6") White HR-12B-BR (x19' 6") Bronze HR-12B-BK (x19' 6") Black</p> 	<p>Top Cap HR-7 <i>mates with HR-2</i> Mill Order</p> 
<p>Top Cap HR-14 <i>mates with HR-2; bundle of 12</i> HR-14-WH (x20') White HR-14-BR (x20') Bronze</p> 	<p>1.75 x .75 Rect. Tube x 20' <i>(for light post)</i> 52-61-1742 1.5 x 1 Rect. Tube x 20' <i>(for heavy post)</i> 52-61-1741</p> 

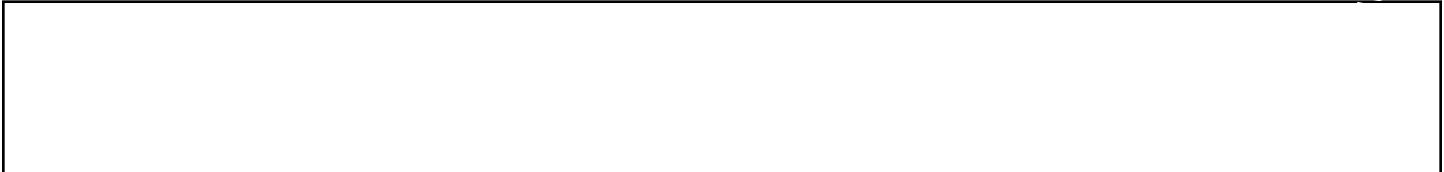

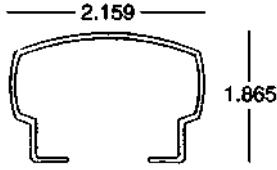
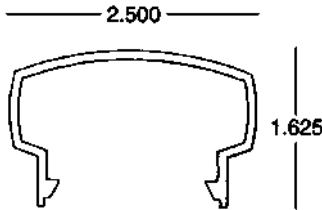
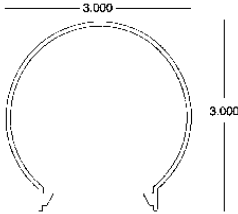
Outer Sleeve**HR-1A***mates with HR-1***Mill Order****Quik Rok****61-00-001***Anchoring Cement**Available in 5 Gallon Buckets***Top Cap x 20'****52-61-1728** White**HR-1****Chemmasters P.A.C.****61-00-000***Anchoring Cement**Available in 5 Gallon Buckets***Top Cap***mates with HR-2***HR-17-WH** (x20') White**HR-17-BR** (x20') Bronze**HR-17****Touch Up Spray Paint***13 ounce cans***35-00-100**

White

35-00-105

Bronze

35-00-110

Ivory

35-00-115

Beige

Square Aluminum Painted Tube - 6063-T6

<u>Stock Code</u>	<u>Size in Inches</u> (E x M x S color)	<u>Approx.</u> <u>Wt/Lin ft.</u>
19-WH-204	2 x .093 x 24' White	0.851
19-MB-204	2 x .093 x 24' Bronze	0.851
19-BK-204	2 x .093 x 24' Black	0.851
19-WH-305	2 x .125 x 24' 6" White	1.125
19-MB-305	2 x .125 x 24' 6" Bronze	1.125
19-COLOR-212	2 x .250 x 24' **	2.100
19-WH-003	3 x .093 x 24' White	1.298
19-MB-100	3 x .093 x 24' Bronze	1.298

** WH: White, MB: Bronze; BK:Black

Square Tube (continued) - 6063-T6

<u>Stock Code</u>	<u>Size in Inches</u> (E x M x S color)	<u>Approx.</u> <u>Wt/Lin ft.</u>
19-WH-225	3 x .125 x 20' White	1.726
19-WH-220	3 x .125 x 24' White	1.726
19-MB-225	3 x .125 x 20' Bronze	1.726
19-MB-235	3 x .125 x 24' Bronze	1.726
19-WH-245	4 x .125 x 20' White	2.325
19-WH-400	4 x .125 x 24' White	2.325
19-MB-245	4 x .125 x 20' Bronze	2.325
19-MB-246	4 x .125 x 24' Bronze	2.32

Handrailing 04

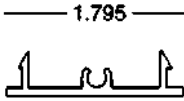
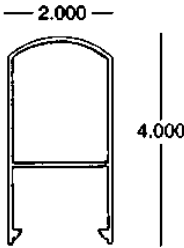
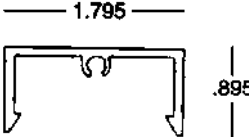
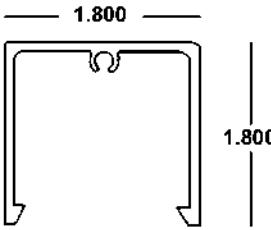
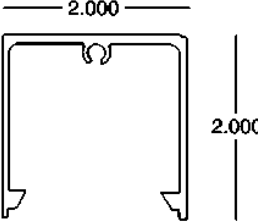
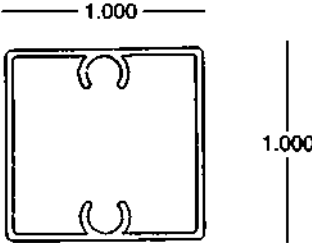
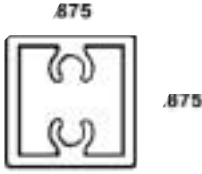
<p>Snap Plate x 21' 1" 52-61-1729 White</p> <p style="text-align: right;">HR-2</p> 	<p>Top Cap <i>mates with HR-2</i> HR-8-WH x (20') White HR-8-BR x (20') Bronze</p> <p style="text-align: right;">HR-8</p> 
<p>Bottom Rail x 19' 6" 52-61-1730 White</p> <p style="text-align: right;">HR-3</p> 	<p>Heavy Post x 21' 1" Mill Order White</p> 
<p>Light Post x 21' 1" 52-61-1732 White</p> <p style="text-align: right;">HR-4</p> 	<p>Light Picket x 23' Mill Order White</p> <p style="text-align: right;">HR-5</p> 
<p>Heavy Picket x 23' Mill Order White</p> 	

2 5/8" x 1" Hollow Dixie Cap

accepts 3/4" & 1" Pickets; 2 x 7/16" Channel;
2" Post

28-63-290

wt/ft: 0.558; length: 25' 10"

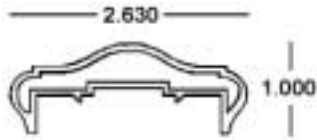

2 5/8" x 1 1/2" Hollow Dixie Cap

accepts 3/4" & 1" Pickets; 2 x 7/16" Channel;
2" Post

28-63-295

wt/ft: 0.665; length: 25' 10"

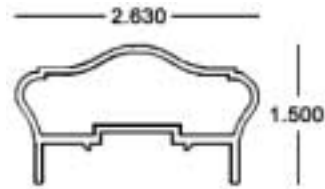

Outside Sleeve

mates with 2 5/8" x 1" Hollow Dixie Cap

28-63-291

wt/ft: 0.500; length: 25' 10"

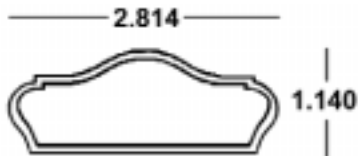

Outside Sleeve

mates with 2 5/8" x 1 1/2" Hollow Dixie Cap

28-63-296

wt/ft: 0.671; length: 25' 10"

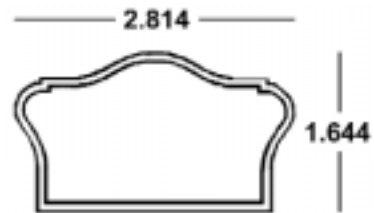

Mill Order

***157**

accepts 1 1/4" Channel

wt/ft: 1.180; length: 20'

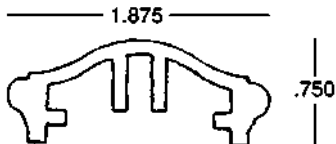

2 1/4" Dixie Cap

with screw boss

28-63-111

wt/ft: 0.722; length: 20'

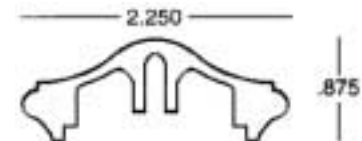

Pipe Bracket 160
31-63-105
 wt/ft: 1.853; length: 16'

A cross-sectional diagram of a pipe bracket. It features a vertical stem on the left that curves into a horizontal flange. The flange has a top edge that is slightly curved upwards. Dimension lines indicate: 2.937 for the stem diameter, 2.875 for the top flange width, and 3.499 for the total width of the flange.

Pipe Bracket 162
31-63-120
 wt/ft: 2.012; length: 16'

A cross-sectional diagram of a pipe bracket. It features a vertical stem on the left that curves into a horizontal flange. The flange has a top edge that is slightly curved upwards. Dimension lines indicate: 2.875 for the stem diameter, 2.500 for the top flange width, and 3.875 for the total width of the flange.

Pipe Bracket 163
31-63-135
 wt/ft: 1.940; length: 16'

A cross-sectional diagram of a pipe bracket. It features a vertical stem on the left that curves into a horizontal flange. The flange has a top edge that is slightly curved upwards. Dimension lines indicate: 2.875 for the stem diameter, 2.250 for the top flange width, and 3.875 for the total width of the flange.

T4 Temper (for bending)

<u>Stock Code</u>	<u>Size in Inches</u>	
	<u>Approx. (Size x OD x ID x Wall)</u>	<u>Wt/Lin ft.</u>
18-63-231 .140 x 24'	1 1/4 x 1.660 x 1.380 x	0.786
18-T4-500 .145 x 24'	1 1/2 x 1.900 x 1.610 x	0.940